



## Guide 3 Shading Out the Heat

A Townsville home cannot be thought of as sustainable unless it can provide shade to all the windows in the house.

In Townsville's sun-drenched climate, shade is essential for reducing the effects of heat on the home. Incorporating shade is a simple and cost-effective way to help keep your house cool year round.

### Introduction

Direct sunlight onto and into the home will rapidly turn your house into an oven. A well-shaded Townsville home will be automatically cooler and more comfortable to live in than a home that has walls and windows that are exposed to the sun.

Historically, a full verandah around the house was typically the best way of providing full shade (Figure 1). However, nowadays this may not be possible due to smaller lot sizes, increased building costs and planning restrictions. Fortunately, there are other ways of providing effective shading without the need for a full wrap-around verandah.



Figure 1 Full wrap-around verandah (Photo: TCC).

Protecting your home from the sun requires planning. This guide will assist by:

1. Introducing effective shading solutions for each side of the home; and
2. Suggesting other helpful shading tips.

### 1. Effective Shading for Different Sides of the House

Understanding the movement of the sun, and how it strikes the house at different angles, is necessary for creating effective shading. For example, during summer at noon the sun is high in the sky, whereas in the morning and afternoon it is closer to the horizon and lower in the sky.

Consequently, when the sun is high in the sky it affects the north and south aspects of the home. When the sun is closer to the horizon it affects the east and west-facing aspects. In each case the sun will penetrate the home at different angles as it moves throughout the day (Figure 2).

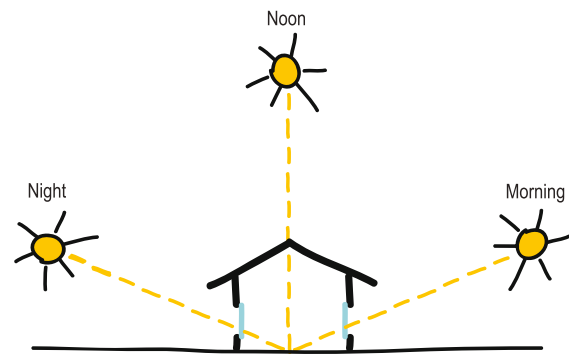

Figure 2 Angles of the sun in the morning, noon and afternoon. For more detail on the sun's movement refer to Guide 1 – Orientation for Townsville Homes.

### North and South-Facing Aspects

North and south-facing aspects are most affected when the sun is high overhead. North-facing aspects should be given the highest priority as it is exposed to the sun all year not just in summer. The best way to provide shade to a north or south-facing aspect (Figure 3) is with a horizontal shade device or structure.

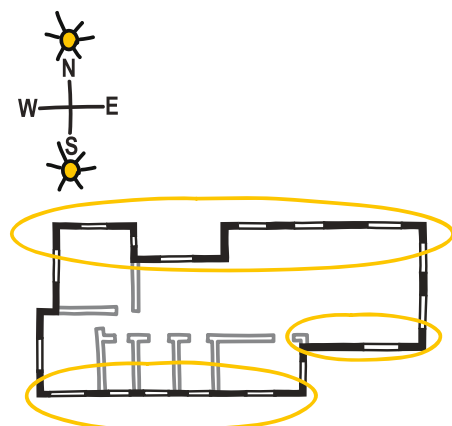

Figure 3 North and South-facing aspects on a house.

Some examples of appropriate horizontal shade structures include:

### Roof Overhangs

Current trends in housing have seen roof overhangs reduced in size and in some cases, removed altogether. This exposes walls and windows to more direct sunlight (Figure 4).

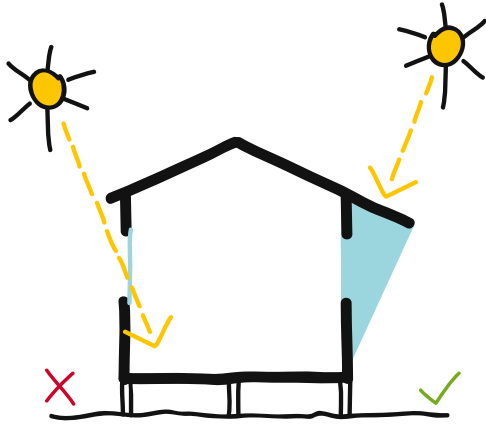

Figure 4 Large roof overhangs will shade north and south-facing walls.

During the middle of the day, when the sun is at its highest, a roof overhang of 900mm will provide the corresponding wall with 100% shade. A return to traditional wider overhangs will better shield north and south sides of the home.

### Pergolas

Covered pergolas, whether fixed to the home or free-standing, are very effective in providing shade from the high overhead sun. They are particularly useful for shading north and south-facing walls and north-facing outdoor entertainment areas.

Pergolas are versatile in that they can be covered with hard materials such as corrugated iron or climbing plants which, if deciduous, have the added bonus of allowing the sun through in winter if desired (Figure 5).

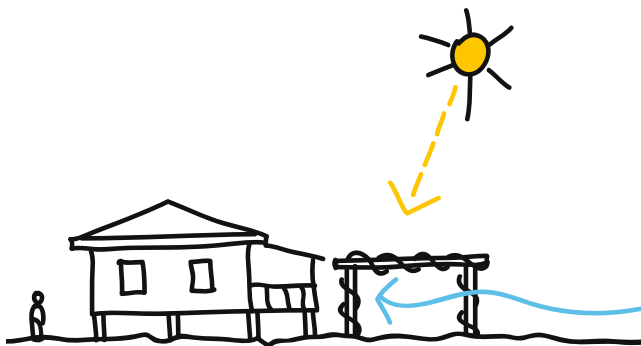

Figure 5 Pergolas are most useful when providing shade from high-angle sun on north or south-facing areas.

### Awnings

If a roof overhang is not possible, a horizontal awning over the window will provide the required shade (Figure 6).

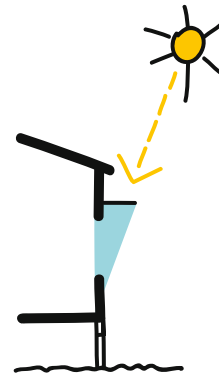

Figure 6 Effective horizontal shading to a window.

To increase the efficiency of horizontal window shading, the shading structure should be wider than the window (Figure 7).

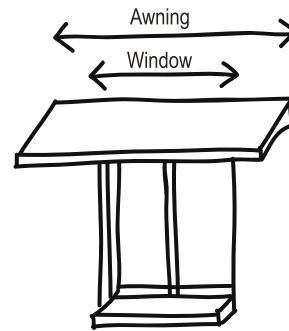

Figure 7 Effective horizontal shading will extend either side of a window.

Using any of the examples above will provide worthwhile shading for the north and south-facing aspects. As a result the home will be protected from the overhead sun and will therefore remain cooler.



### FACT 1

Direct sun on a square metre of building surface has the equivalent effect as pointing a single bar radiator at that same square metre.

### East and West-Facing Aspects

For east and west aspects the sun will be low in the sky for long periods (Figure 8). This means that the sun will come in underneath horizontal shade devices making them ineffective.

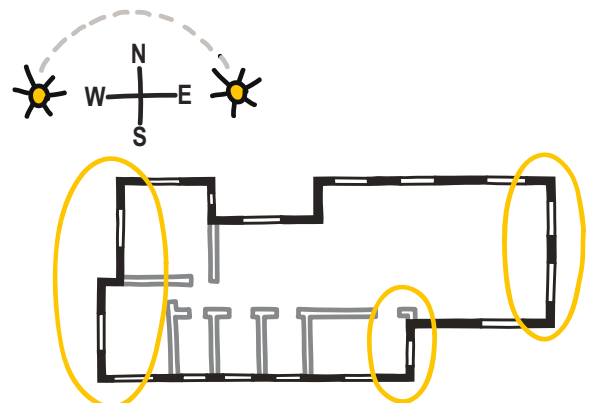

Figure 8 East and west-facing aspects. The morning and afternoon.

In the morning the low-angled sun will heat up east-facing rooms, quickly transferring heat throughout the house. If the house absorbs heat in the morning it becomes extremely difficult to keep the home cool as the day heats up.

In the afternoon, low-angled sun on a west-facing wall is a significant problem. If the sun is allowed to penetrate deep inside the home during, or shortly after, the hottest parts of the day it will cause excessive heat gain.

This heat gain will be stored and re-radiated well into the night making west-facing rooms hot and uncomfortable.

Vertical shading devices are essential to stop the low angled sun heating the walls and penetrating inside the home. Utilising these shading structures on east and west-facing aspects of the home will significantly reduce the amount of heat absorbed by the home (Figure 9).



**Figure 9** An example of how effectively the vertical screen shades the window from low-angled sun.

Vertical shading can be in the form of lattice screens, timber batten screens (Figure 10), aluminium batten awnings, egg-crate shading or mixed height plantings of shrubs and trees.

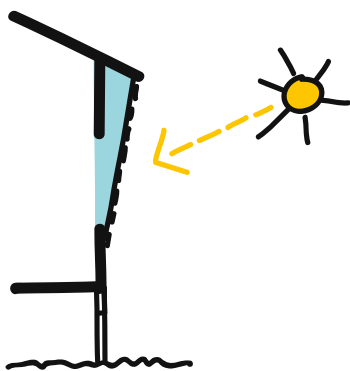
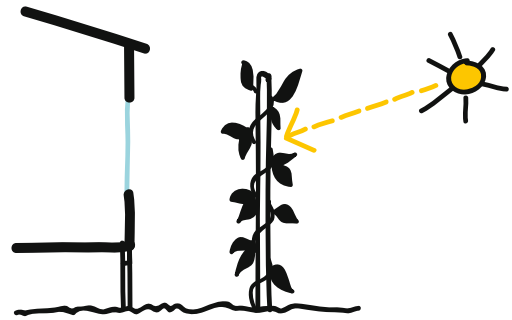

**Figure 10** An example of a vertical timber batten screen, attached to the house, providing shade for a window.

Some common examples of useful vertical shade structures include:

### Trellises and Screens

When space is limited, a vertical trellis or lattice screen covered with climbers is a common and effective method for shading east and west-facing walls (Figure 11).



**Figure 11** Trellis or lattice screens are effective for shading east and west-facing aspects.

### Pergolas and Verandahs with Vertical Structures

Roof overhangs, pergolas and verandahs which incorporate vertical structures, such as screens, lattice and vertical awnings are also a good method to block the sun from east and west-facing walls and windows (Figure 12). This type of screening can also include blinds, vegetation or trellising.

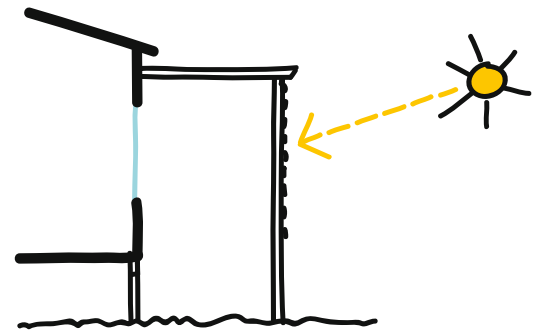

**Figure 12** An example of an east or west-facing pergola with a vertical screen to block low-angle sun.

### North-Eastern and North-Western Facing Aspects

On north-eastern and north-western aspects (Figure 13) the sun is midway in the sky at mid-morning and mid-afternoon.

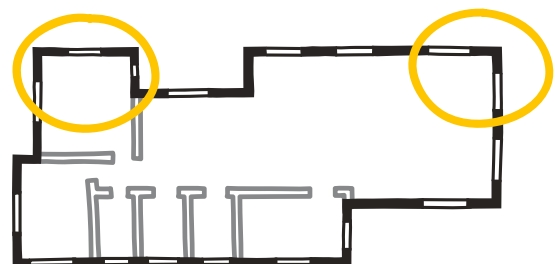
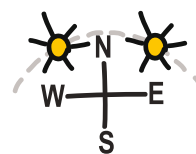

**Figure 13** North-eastern and north-western aspects.

This means that shading devices forward of the building line are the best way to protect windows and walls from the sun. This form of shading should extend past the north wall of the house.

Forward shading could take the form of landscaping (such as trees and bushes to form a mixed canopy), a blade wall or the combination of a blade wall and mixed canopy (Figure 14). However, be careful not to block prevailing breezes from the north-east.

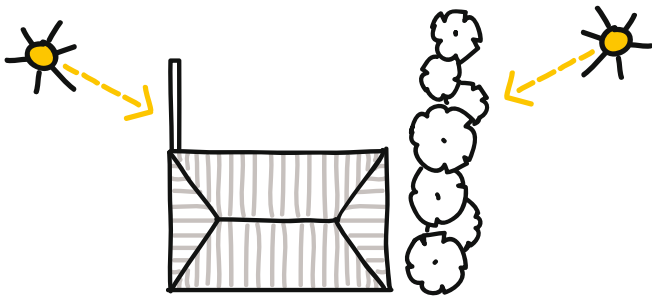

Figure 14 Forward shading using a blade wall (left) and mixed canopy (right).

## 2. Other Helpful Shading Tips

### Prioritise Shading of Thermal Mass Surfaces

Thermal mass surfaces around the home include concrete, block, brick or stone walls, paving, concrete and bitumen driveways. Thermal mass materials in direct sunlight absorb and store heat then slowly release it over many hours.

Use a variety of shading methods to provide shade to thermal mass materials around your home. Keeping these materials out of the sun will help to keep the air around your home cool.

Avoid locating unshaded driveways and paving in front of prevailing breezes, as air passing over the surface will heat up before entering your home (Figure 15).

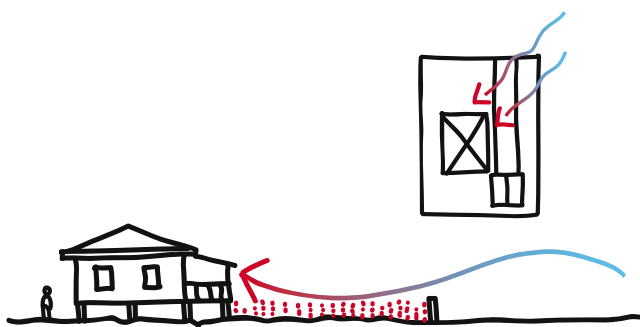

Figure 15 Unshaded paved areas radiate heat and will heat up breezes travelling across them.

For additional information on thermal mass material refer to Guide 5 - Building Materials and Insulation for Townsville Homes.

### Natural Shading

Plants can be a great form of shading. They can be used in conjunction with other shading devices or on their own.

For additional information on natural shading refer to Guide 4 - Landscaping: An Integral Aspect of Sustainability.

## Adjustable Shading

Adjustable shading allows the user to adjust the desired level of shade throughout the year. Adjustable shading devices can include awning blinds (Figure 16), conventional or roller shutters, adjustable angled slats and removable shade-cloth over pergolas.



Figure 16 An example of adjustable shading.

In any scenario, if it is not possible to shade the entire wall, irrespective of what side of the house it is on, then shading the windows is essential. Protecting windows from the direct sun will make a significant difference to the comfort of your home.



### FACT 2

Unshaded glass is the single greatest source of unwanted heat in a home. When sun passes through glass it is absorbed by building elements and furnishings, which then re-radiate it at a different wavelength. This new wavelength cannot pass back out through glass and is 'trapped' within the house. This is often referred to as the greenhouse effect which results in higher temperatures indoors compared to outdoors.

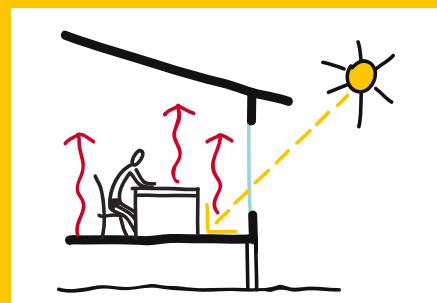

The addition of some shade structures may require building approval. Check before you start. By incorporating as many of the ideas presented here as possible you will maximise the cooling effects of shade and reduce your energy consumption.



### CONTACT

Planning Services  
Special Projects Unit  
Ph: 4727 9000 Fax: 4727 9052  
www.townsville.qld.gov.au

